

Approval body for construction products
and types of construction

Bautechnisches Prüfamt

An institution established by the Federal and
Laender Governments



European Technical Assessment

ETA-17/0449
of 25 October 2017

English translation prepared by DIBt - Original version in German language

General Part

Technical Assessment Body issuing the
European Technical Assessment:

Trade name of the construction product

Product family
to which the construction product belongs

Manufacturer

Manufacturing plant

This European Technical Assessment
contains

This European Technical Assessment is
issued in accordance with Regulation (EU)
No 305/2011, on the basis of

Deutsches Institut für Bautechnik

LS 90/ RS 90

Construction product for use in penetration seals

KAISER GmbH & Co. KG
Ramsloh 4
58579 Schalksmühle
DEUTSCHLAND

KAISER GmbH & Co. KG
Ramsloh 4
58579 Schalksmühle
DEUTSCHLAND

10 pages including 6 annexes which form an integral part
of this assessment

ETAG 026 Part 2: "Penetration Seals",
used as EAD according to Article 66 Paragraph 3 of
Regulation (EU) No 305/2011.

The European Technical Assessment is issued by the Technical Assessment Body in its official language. Translations of this European Technical Assessment in other languages shall fully correspond to the original issued document and shall be identified as such.

Communication of this European Technical Assessment, including transmission by electronic means, shall be in full. However, partial reproduction may only be made with the written consent of the issuing Technical Assessment Body. Any partial reproduction shall be identified as such.

This European Technical Assessment may be withdrawn by the issuing Technical Assessment Body, in particular pursuant to information by the Commission in accordance with Article 25(3) of Regulation (EU) No 305/2011.

Specific Part

1 Technical description of the product

The construction product "LS 90/ RS 90" is a moulded part made of an intumescent material which expands under heat exposure.

Detailed specifications and fire safety related performance criteria in relation to the construction product are given in Annex 1.

NOTE:

The characteristics listed are suitable both for identifying the construction product as well as for performing the manufacturer's factory production control.

2 Specification of the intended use in accordance with the applicable European Assessment Document

"LS 90/ RS 90" is intended for use as a component with a fire protection effect in penetration seals that are subject to fire safety requirements. Heat transmission and fire spread of fire are restricted in the event of fire due to the intumescent effect of the construction product.

Construction products for penetration seals are used to seal openings in fire-resistant walls and ceilings, which are penetrated by pipes.

Penetration seals are building components which prevent the passage of heat and the spread of fire in areas where fire-resistant walls are penetrated by services.

This ETA has served to verify the resistance to fire of cables which were fed through fire-resistant walls and consisted of the construction products listed in Annex 1.

The penetration seal consisted of two moulded parts of which one was arranged on each side of the wall.

More detailed information and data on the verified penetration seals are given in Annexes 1 to 6.

The construction product "LS 90/ RS 90" may be used for penetration seals in dry interior areas and temperatures above 0° C (use category type Z₂).

The performance data in Section 3 relates only to the penetration seals tested as part of this assessment (e.g., regarding the design and arrangement of the penetration seal components and the type and position of the service lines).

3 Performance of the product and references to the methods used for its assessment

3.1 Safety in case of fire (BWR 2)

Essential characteristic	Performance
Reaction to fire	Reaction to fire classification of the intumescent material in accordance with EN 13501-1: class E
Resistance to fire of a penetration seal containing the product	The resistance to fire depends on how the penetration seal is designed and/or installed and the installation conditions. More details on the tested penetration seals and the related fire resistance classes are given in Annexes 1 to 7.

4 Assessment and verification of constancy of performance (AVCP) system applied, with reference to its legal base

In accordance with the European Technical Approval Guideline "Fire Stopping and Fire Sealing Products", ETAG 026, Part 2: "Penetration Seals", August 2011, which is used as European Assessment Document (EAD), the following legal base shall apply: 1999/454/EC.

The system to be applied is: system 1.

5 Technical details necessary for the implementation of the AVCP system, as provided for in the applicable EAD

Technical details necessary for the implementation of the AVCP system are laid down in the control plan deposited with Deutsches Institut für Bautechnik.

Issued in Berlin on xx month yyyy by Deutsches Institut für Bautechnik

Prof. Gunter Hoppe
Head of Department

beglaubigt:
Bisemeier

Properties and performances criteria of the construction product "LS 90/ RS 90"

Component	Properties
Moulded part	Dimension: see annexes 2 and 3 Material: Intumescent building material (The material specifications are deposited at the DIBt) Classification of the fire behavior according to EN 13501-1: Class E

The properties listed can be used both for the identification of the construction product and for the implementation of the factory production control of the manufacturer.

Implementation details for the factory production control are included in the inspection plan.

Performance of penetration seals, comprising the construction product "LS 90/ RS 90"

	Essential requirement	Test method	Construction of the sample	Performance acc. to. EN 13501-2
1	Resistance to fire	EN 1366-3	100 mm thick flexible wall; design and layout of the penetration seal according to annex 4*	EI 90
2	Resistance to fire	EN 1366-3	100 mm thick flexible wall; design and layout of the penetration seal according to annex 5*	EI 90
3	Resistance to fire	EN 1366-3	100 mm thick flexible wall; design and layout of the penetration seal according to annex 6*	EI 90

* Illustrations without guarantee for completeness

The use of the construction product "LS 90 RS 90" in penetration seals shall be in accordance with national requirements for planning, design and execution and in accordance with the installation instruction of the manufacturer.

The tested/ illustrated seals are only examples for the use.

LS 90/ RS 90

Properties and performances

Annex 1

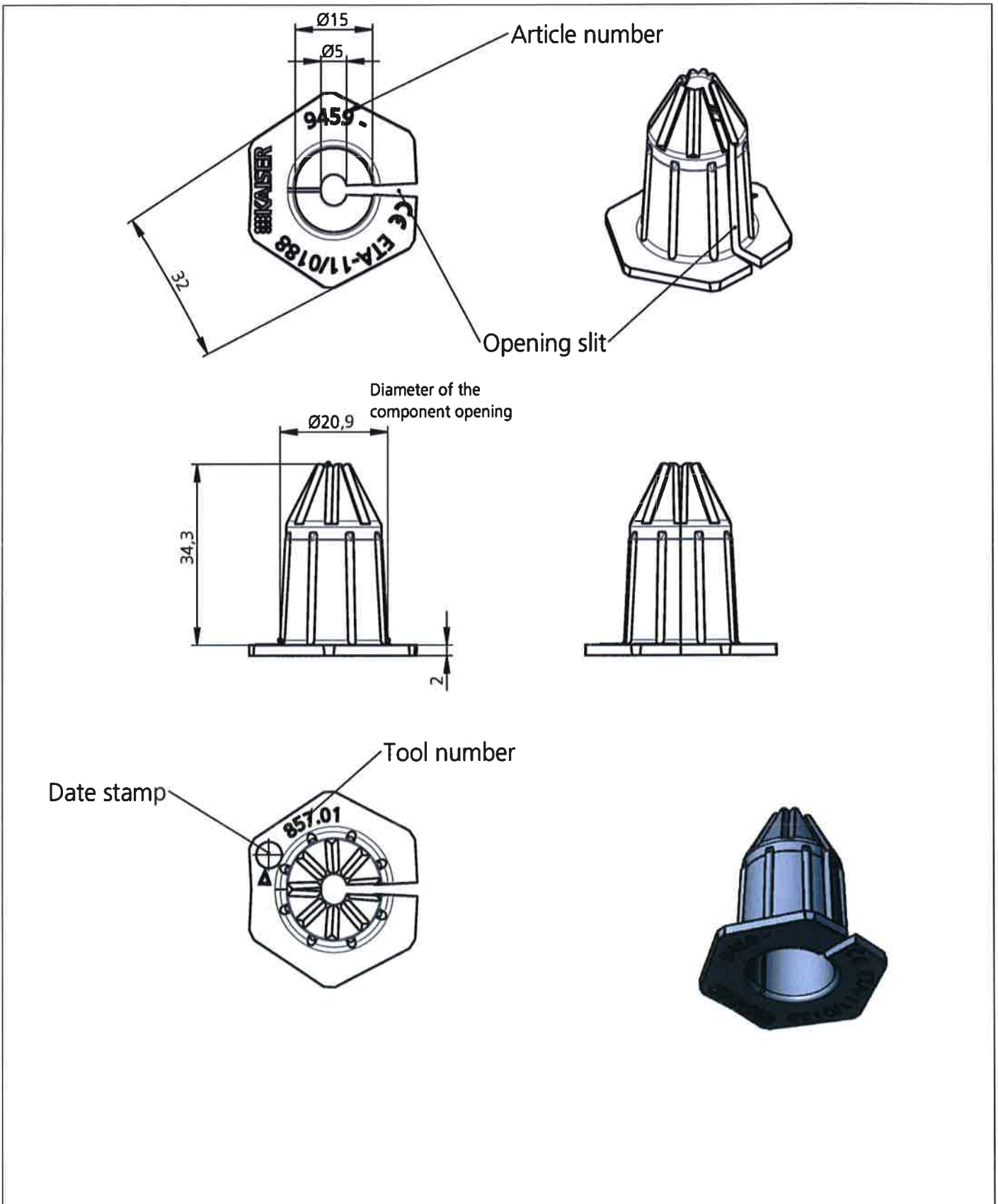

LS 90/ RS 90

Moulded part "LS 90"

Annex 2

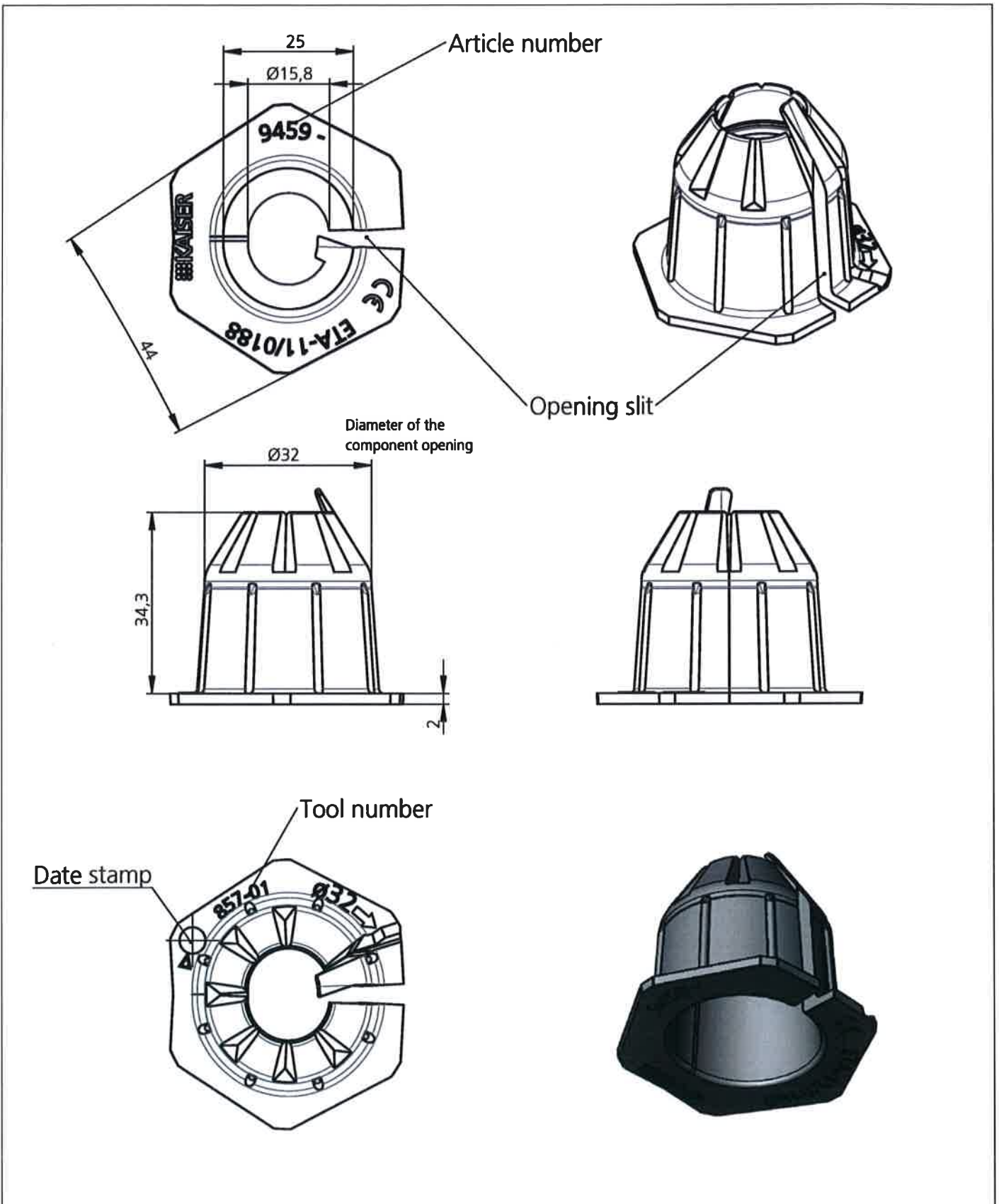

LS 90/ RS 90	Annex 3
Moulded part "RS 90"	

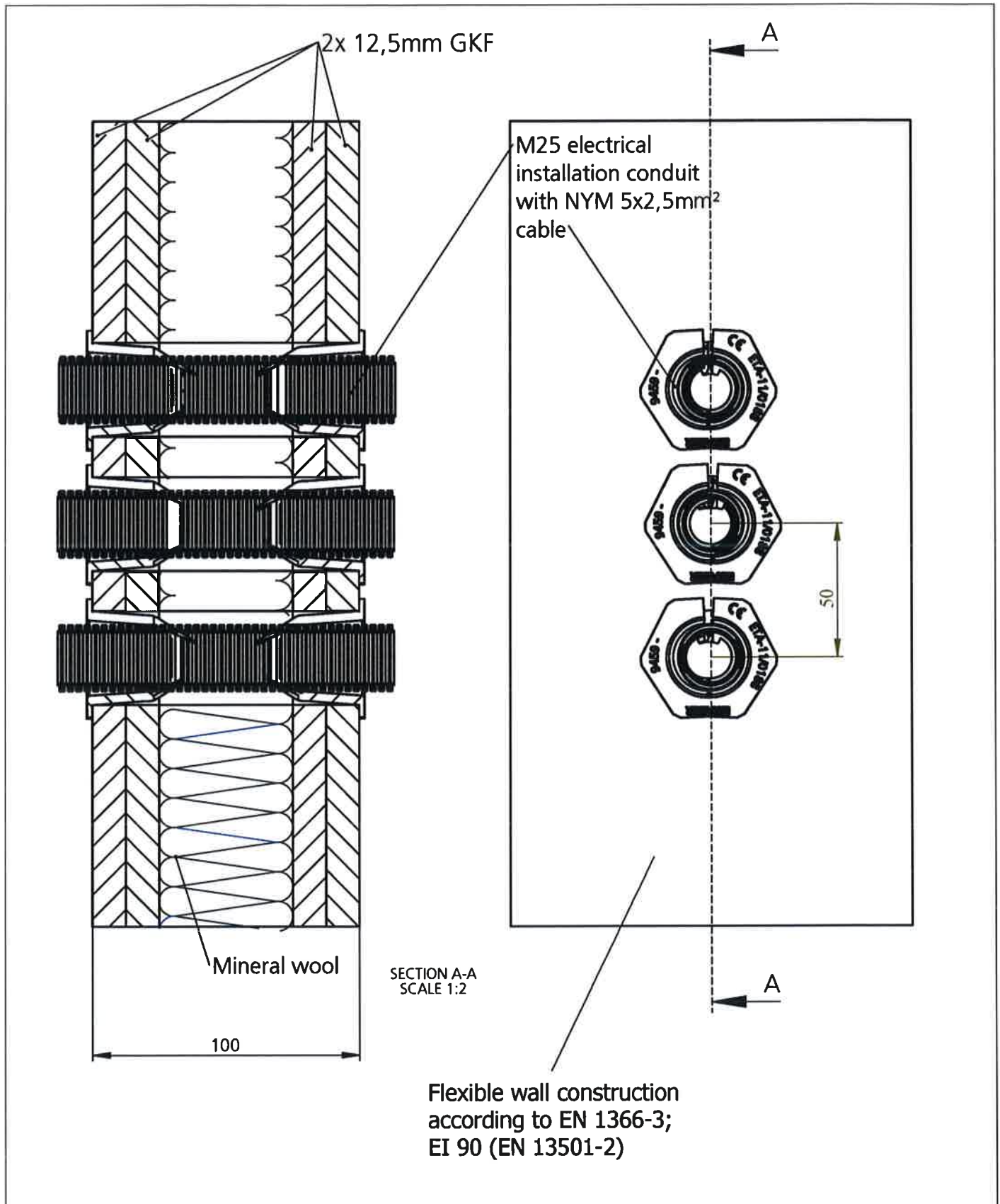

LS 90/ RS 90

Example for a cable penetration seal of the fire resistance class EI 90, using moulded part "RS 90"

Annex 4

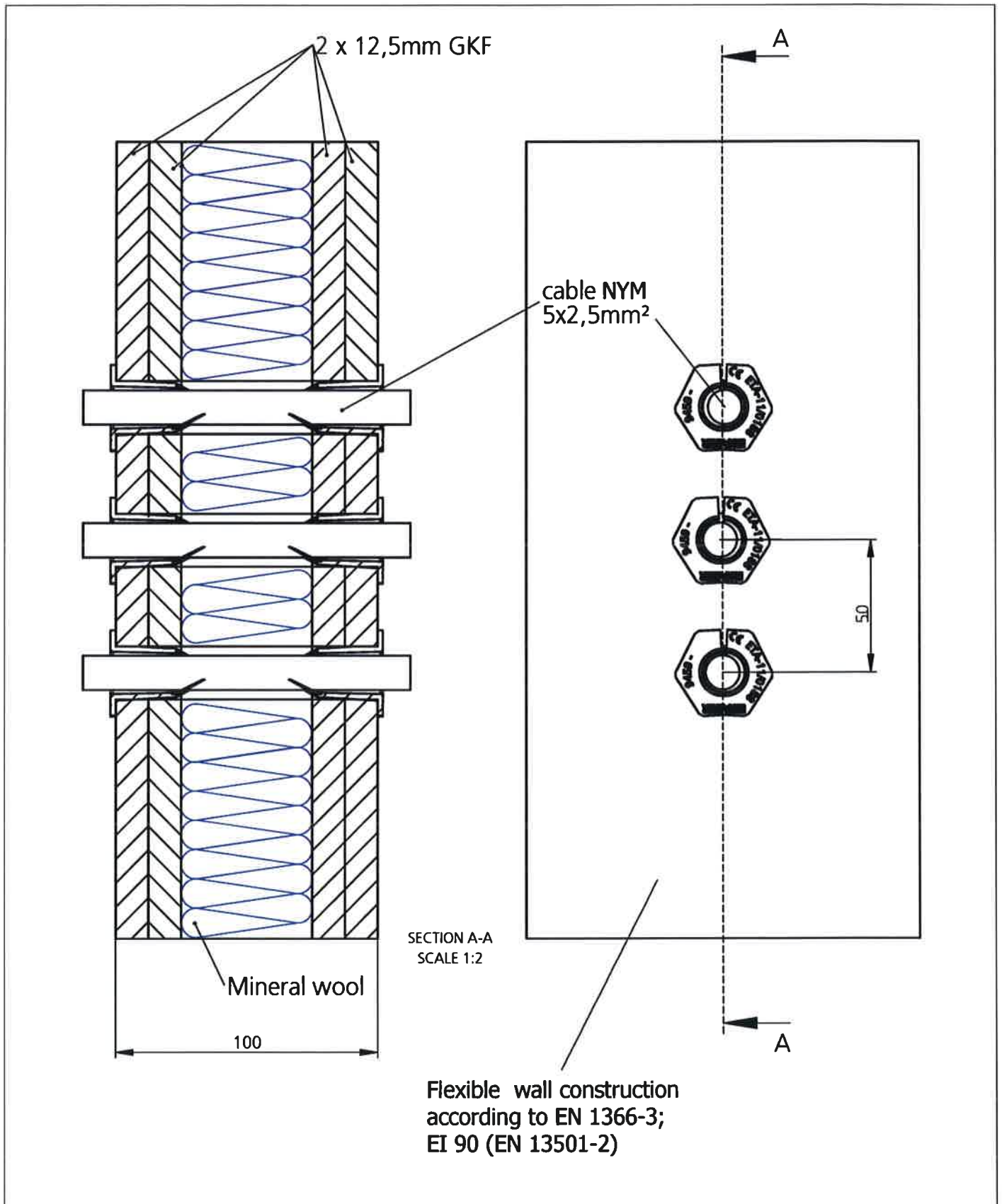

LS 90/ RS 90

Example for a cable penetration seal of the fire resistance class EI 90, using moulded part "LS 90"

Annex 5

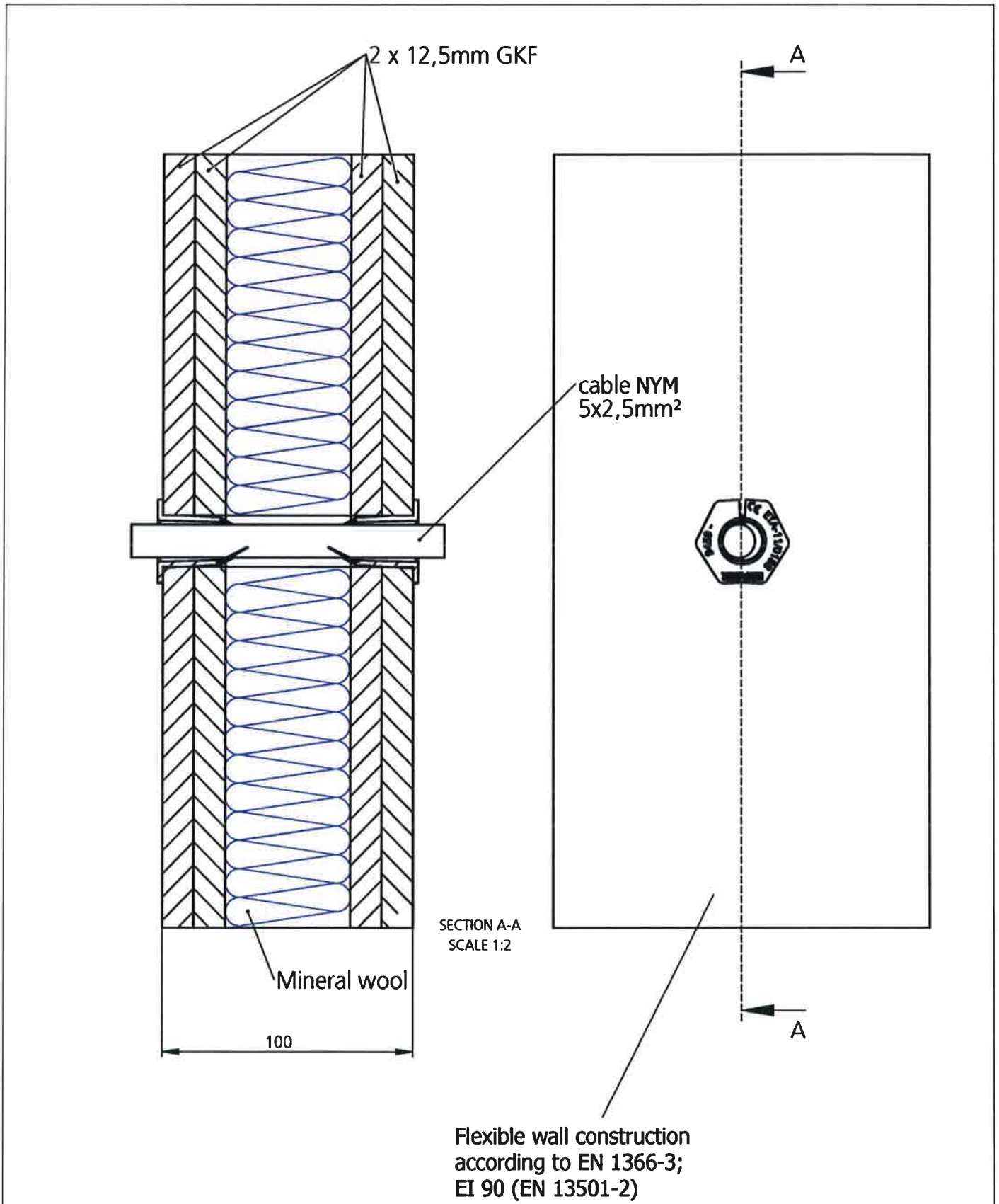

LS 90/ RS 90	Annex 6
Example for a cable penetration seal of the fire resistance class EI 90, using moulded part "LS 90"	